

MODEL NUMBER	IEEE5-36-184TC		
HORSEPOWER	5		
RPM / POLES	3600 / 2		
VOLTAGE / PHASE	460 / 3		
FRAME	184TC		
ENCLOSURE / DEGREE OF PROTECTION	TEFC / IP56		
FREQUENCY	60 HZ		
FULL LOAD SPEED	3515 RPM		
SERVICE FACTOR	1.15		
INSULATION CLASS	F Class N Varnish		
FULL LOAD AMPS; 460	6.1 A		
LOCKED ROTOR CURRENT (% Full Load)	750 %		
NEMA CODE LETTER	J		
EFFICIENCY / POWER FACTOR	<u>LOAD</u>	<u>EFF.</u>	<u>P.F.</u>
	100 %	88.5 %	86.0 %
	75 %	88.7 %	82.5 %
	50 %	85.0 %	75.0 %
DUTY CYCLE	S1 / Continuous		
TORQUE	<u>FULL LOAD</u>	<u>LRT</u>	<u>BDT</u>
	7.4 lb.ft.	190 %	260 %
NEMA DESIGN	B		
MOMENT OF INERTIA	<u>LOAD (Max.)</u>	<u>MOTOR</u>	
	18.984 lb.ft. <sup>2</sup>	0.166 lb.ft. <sup>2</sup>	
SOUND PRESSURE LEVEL ( No Load 1 M From Motor)	73 dB(A)		
MAX. SHAFT VIBRATION	0.08 In/Sec – Peak Velocity		
NUMBER OF STARTS (Hot / Cold)	2 Hot / 3 Cold		
MAX. AMBIENT TEMPERATURE	40° C		
MAX. ELEVATION	3300 Ft. Above Sea Level		
TEMPERATURE RISE (At Full Load)	80° C		
DRIVE-END BEARING	6206ZC3		
OPPOSITE DRIVE-END BEARING	6206ZC3		
BEARING SEAL TYPE	ProTech™ IP66 Labyrinth On DE and ODE		
GREASE TYPE	Mobil Polyrex EM		
MOUNTING	F1 (F2 Suitable), W6, W8, B3, V5, V6		
ROTATION	Bi-Directional		
APPROXIMATE WEIGHT	105 lbs		
AREA CLASSIFICATION	Class I, Division 2, Groups A, B, C, D, T3A		
PAINT	Epoxy		
INVERTER RATING	10:1 CT / 1000:1 VT		
INSULATION TYPE	Hyundai Inverter Shield, Meets NEMA MG1 Part 31		
SPECIFICATION - In Accordance With	IEEE-841, Version 2009, NEMA, CSA		



CC 038A





1 E E E 8 4 1 TEFC

**THREE PHASE INDUCTION MOTOR**

**TYPE**

LP,JP

CAST IRON FRAME

FRAME SIZE

OUTPUT(HP)

POLES

Hz

TIME RATING

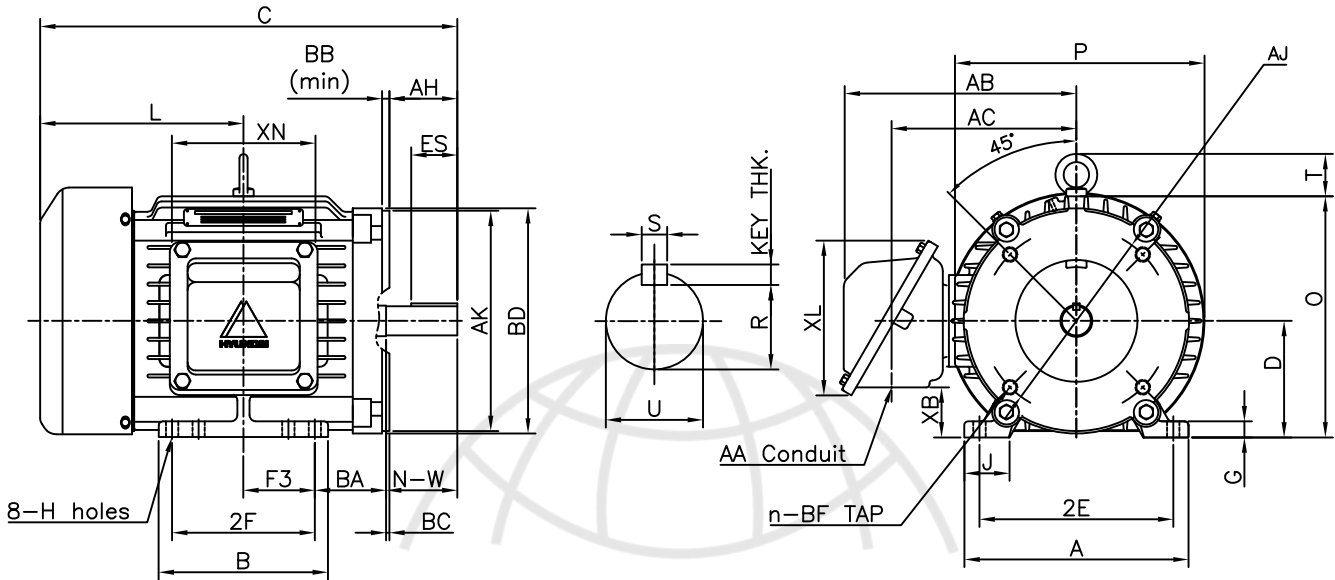

DIMENSIONS

FLANGE							MOUNTING									
AJ	AK	BD	BB	BC	BF	n	A	B	2E	2F	-	F3	G	J	H	
7.250	8.50	8.70	0.25	+0.12	1/2-13	4	8.66	6.54	7.50	5.50	-	2.75	0.62	1.74	0.41	

CONDUIT BOX						OVERALL								APPROX. WGT.(LB)
AA	AB	AC	XB	XL	AB	BA	C	D	L	O	P	T		
0.75	9.06	7.14	1.93	5.97	5.71	2.75	16.12	4.50	7.85	9.32	9.64	1.63	105	

SHAFT						KEY THK.	BEARING	
U	N-W	A-H	KEYWAY				DRIVE END	OPP. DRIVE END
			R	ES	S			
1.125	2.75	2.62	0.986	1.78	0.250	0.250	6206ZZC3	6206ZZC3

**NOTE**

- 1.Dimension "D" tolerance : +0.00inch - 0.03inch
- 2.Dimension "U" tolerance : +0.000inch - 0.0005inch
- 3.Dimension "R" tolerance : +0.000inch - 0.015inch

APPD BY	J.H.KIM	UNIT	INCH	SUBJECT	NEMA 184TC(KIT)	CAD PROJ	FILE	
CHKD BY	N.D.LEE	SCALE	1/8			SCALE-NEMA\A1304AA		
CHKD BY	K.S.LEE	PROJEC'N	3rd Angle	TITLE				OUTLINE
DSND BY	S.W.SEO	DATE	2010.12.20					



REF. NO	350A8304AA	Sheet No.	of
DWG NO	350A8304AA	Revision No.	0



# PERFORMANCE CURVE

CURVE NO.

**P-PKP184SR1**

Type	:	PKP
Full Load Torque	:	7.4 lb.ft
Motor moment of Inertia (J)	:	0.166 lb.ft <sup>2</sup>
Load moment of Inertia (J)	:	18.984 lb.ft <sup>2</sup>

3.7 kW	5 HP	60 Hz	
2 P	Rated Speed :	3515 RPM	
Rated Voltage	575V	460V	230V
Full Load Current	4.9A	6.1A	12.2A

SPEED VS TORQUE & CURRENT CURVE

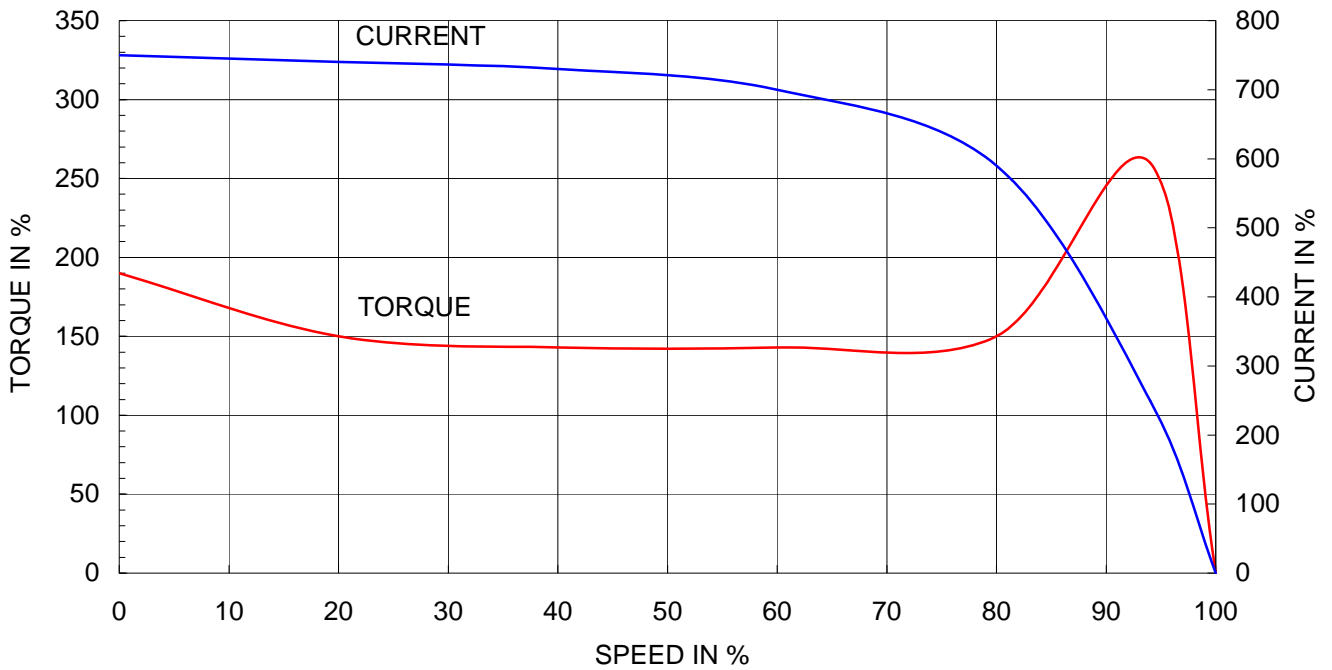

OUTPUT VS EFF., P.F & CURRENT CURVE

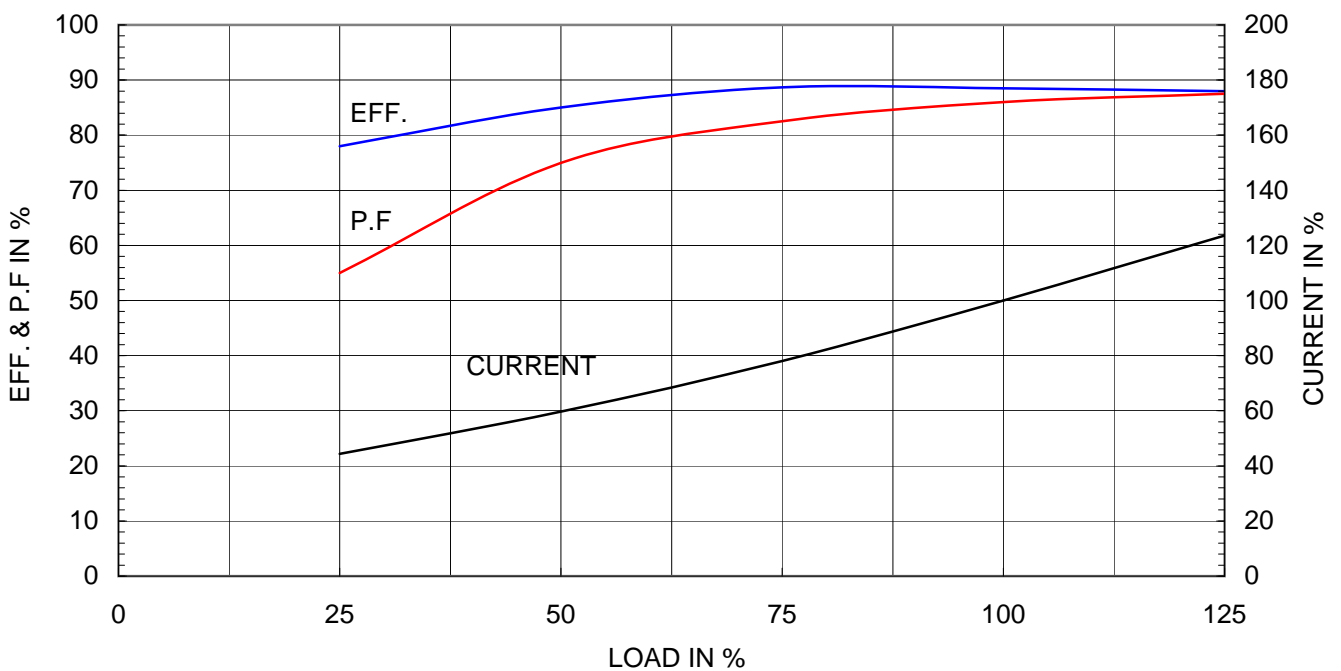



# THERMAL LIMIT & TIME CURRENT CURVE

CURVE NO.

T-PKP5-36-184T

Type :	PKP5-36-184T		5	HP	2	P	60	Hz
FULL LOAD TORQUE :	7.4	lb.ft	RATED SPEED :		3515 rpm			
J OF LOAD :	-	lb.ft²	VOLTAGE		460 V	575 V		
J OF MOTOR :	0.2	lb.ft²	RATED CURRENT		6.1A	4.9A		

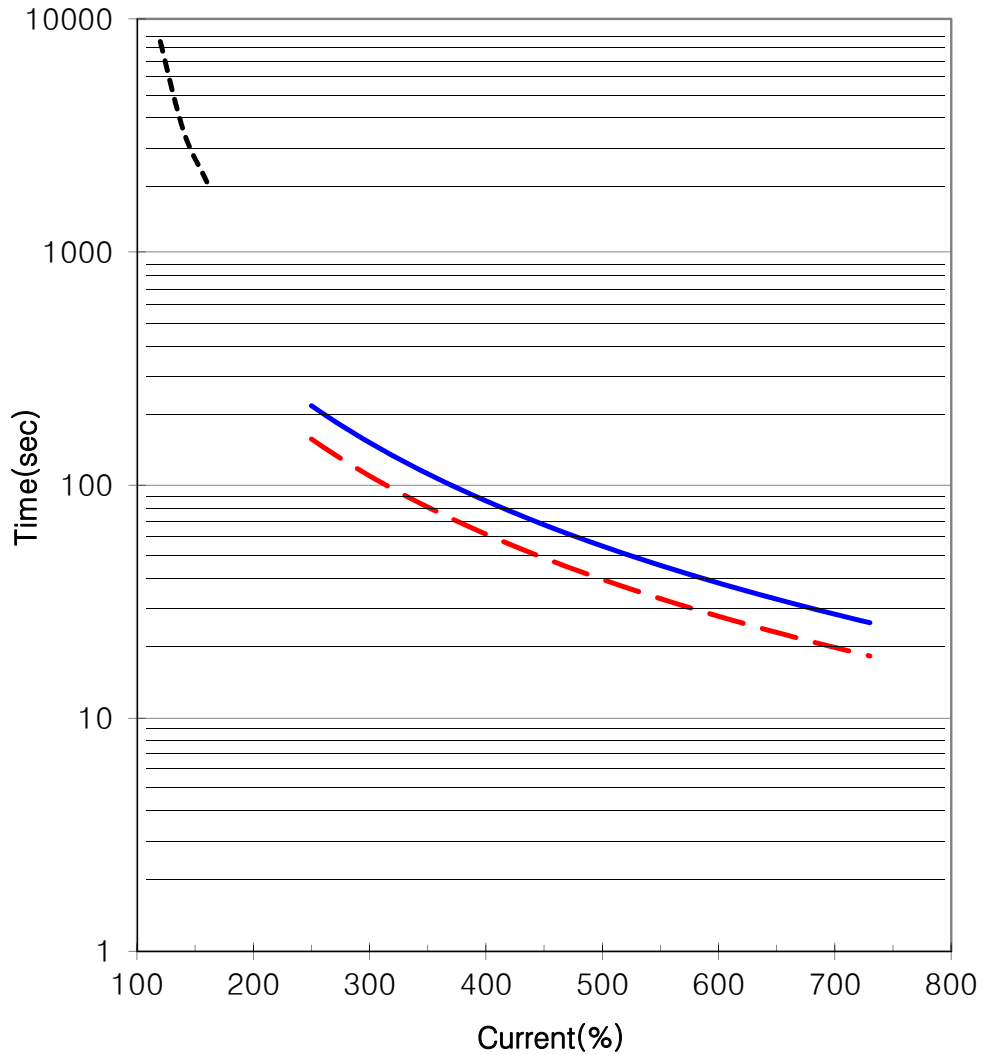

— THERMAL LIMIT CURVE AT COLD CONDITION  
- - THERMAL LIMIT CURVE AT HOT CONDITION

STARTING TIME	SAFE STALL TIME
- at rated voltage starting	18 sec. at Hot condition
- at 80% of rated voltage starting	25 sec. at Cold condition

THIS DRAWING IS PROPRIETARY TO HHI. NO PART OF THIS DRAWING MAYBE REPRODUCED WITHOUT THE PERMISSION OF HHI.

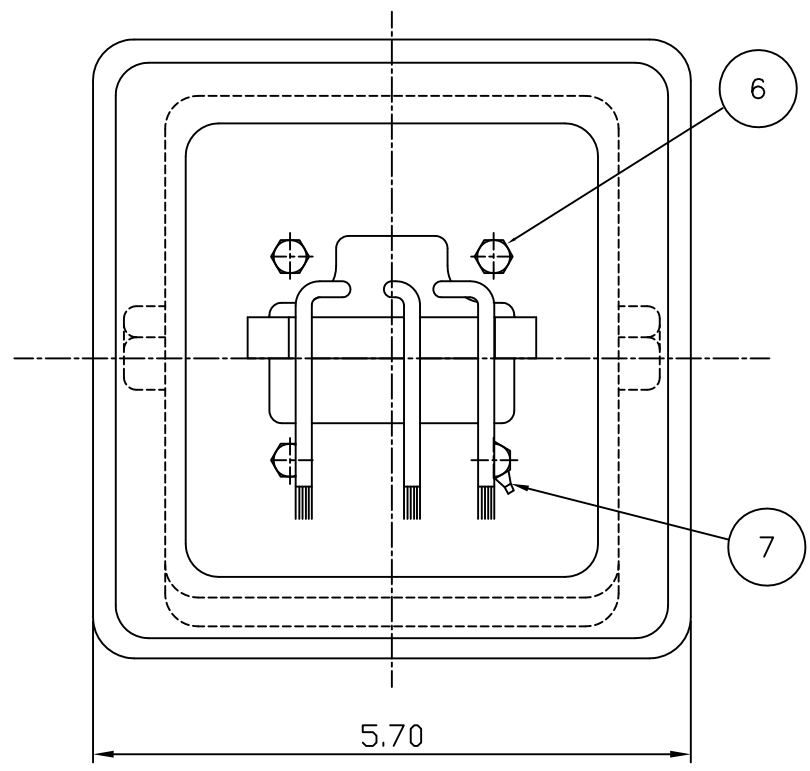
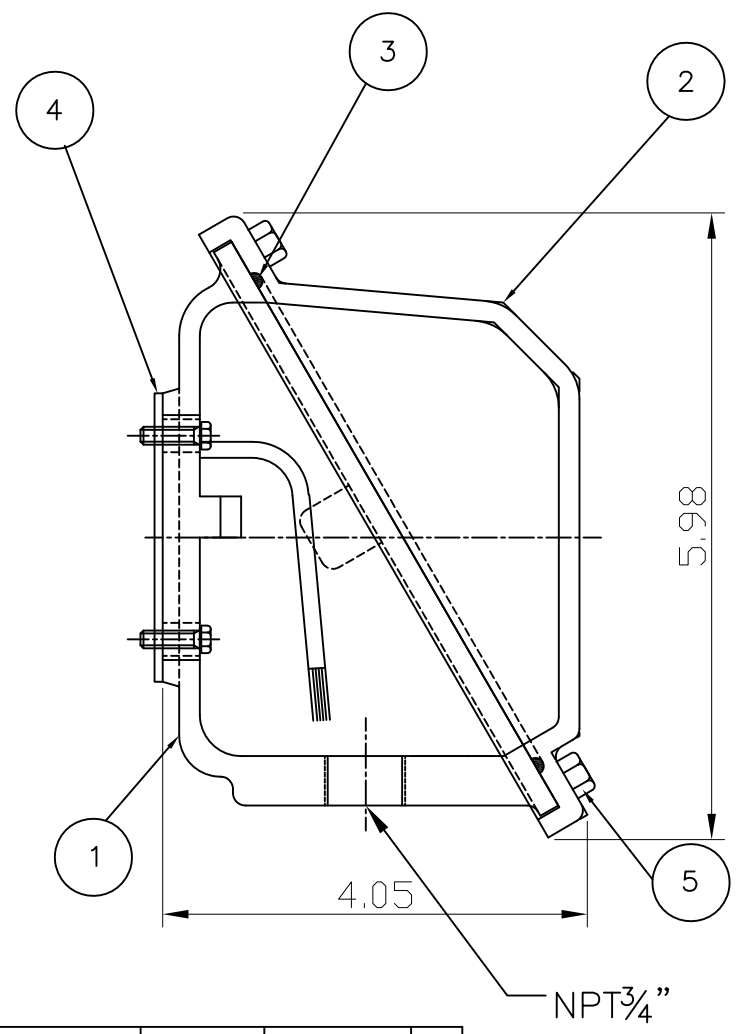

PT	DESCRIPTION	MATERIAL	DIMENSION	Q'TY
1	CONDUIT BOX	FC15	---	1
2	CONDUIT BOX COVER	FC15	---	1
3	O-RING / COVER	EPDM	ø4	1
4	BOX GASKET	NBR	---	1
5	COVER+BOX HEX BOLT	S45C	M6 X L20	4
6	BOX+FRAME HEX BOLT	S45C	M6 X L20	4
7	GROUND TERMINAL LUG	CU	---	1

Q'TY	DESCRIPTION	MATERIAL	DIMENSION	WEIGHT	PART NO.	REMARK	NO.
APPD BY		UNIT	INCH	SUBJECT	NEMA 182/184	CAD PROJ \ FILE	
CHKD BY		SCALE	1:1	227B8008CB2			
CHKD BY	---	PROJEC'N	(3rd Angle)	TITLE			
DSND BY	JEONG JIN SEON	DATE	2007.04.28.	TERMINAL BOX ASSEMBLY			
REF. NO		227B8004NA1		Sheet No.		of	
DWG NO		227B8004NA1		Revision No.		0	



REV	DATE	CONTENTS	REVD BY	CHKD BY	CHKD BY	APPD BY